









300x320 X-CNC-LR-1500

	$\square 0^\circ$	$\square 45^\circ$	$\square 60^\circ$	$\square 45^\circ$	$\square 60^\circ$	$\begin{matrix} b \\ a \times b \end{matrix}$
	300	300	200	280	x	x
	180*	110*	80*	110*	x	x
	320x300	300x250	200x200	260x200	x	260x200

					
3x400V	2,4	20-100	3660x27x0,9		1200
L	B	Hmin	Hmax	V	
2547	4632	1560	2177	941	

*doporučené hodnoty/recommended values

300-F

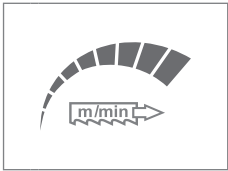

LIGHT L1

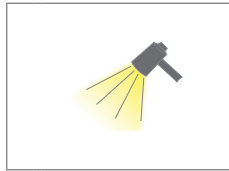

240-CK

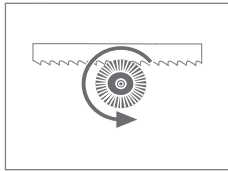

300-DPP

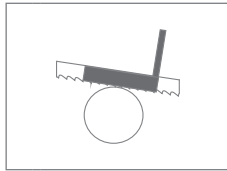

300-RTS-A

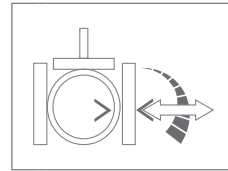

PEGAS-BRP

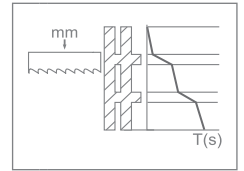

300-PUD



290-HP-A

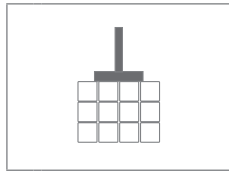

MINI LUBE

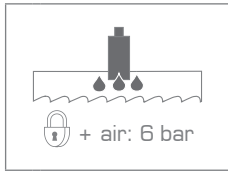

R 390

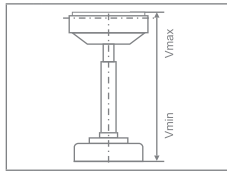

	S (mm)	Vmin (mm)	Vmax (mm)
R	390	760	980

RB 200



RBS 200/390
+RB



RHS 390
+RBS+RB



300-VTT



RD VR-390

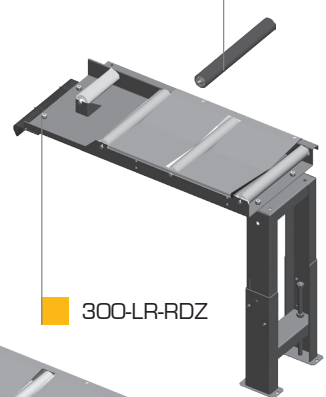

300-SKZ



300-LR-RDZ

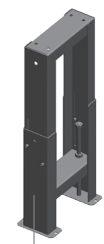

RD 2000/390

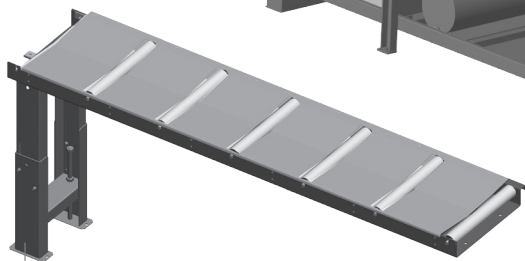

BOX-PCS

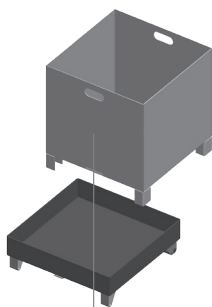

BOX-TAH

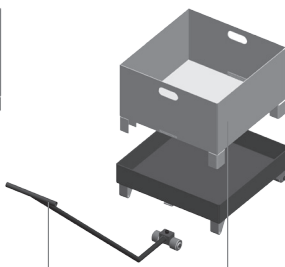

BOX-TRI

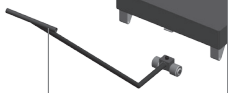

RD 1000/390



RDN

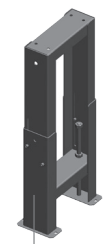

STANDARD

OPTION

PEGAS

PEGAS-GONDA s.r.o., Čs.armády 322, 684 01 Slavkov u Brna, CZECH REPUBLIC
Tel: 00420-544 221 125 (126), Fax: 00420-544 227 389, E-mail: pegas@gonda.cz
www.pegas-gonda.cz

- výrobce si vyhrazuje právo provádět změny technických údajů, technické údaje odpovídají 1.5.2015
/ producer has the right to make changes of technical data, technical data are valid on 1.5.2015 /
- pila na fotografii není vždy v základním provedení, uvedené rozměry odpovídají stroji v základním provedení
/ the machine in the picture is not always in the basic version, mentioned diameters are for machine in basic version /

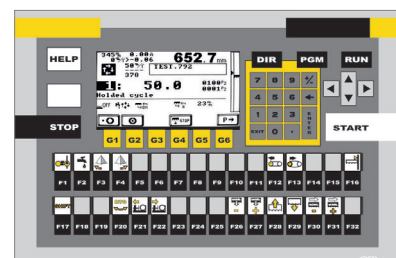

CONTROL PANEL: MAHLER (X)